

DIMENSIONS (CU-HD1300FT)

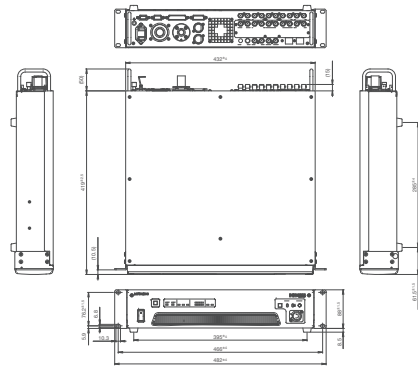

DIMENSIONS (CU-HD500)

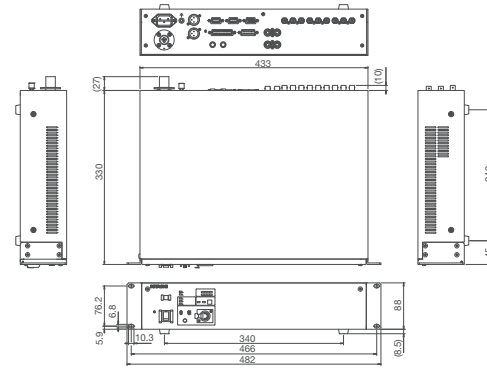

DIMENSIONS (SU-1000)

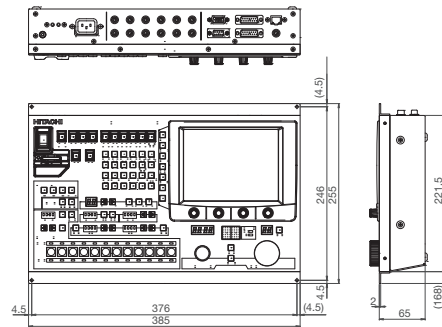

DIMENSIONS (RU-1500JY)

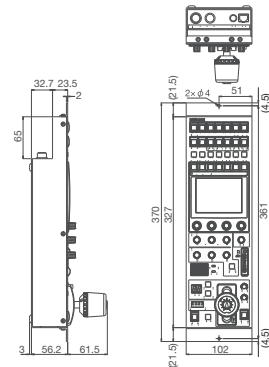

DIMENSIONS (RU-1000VR)

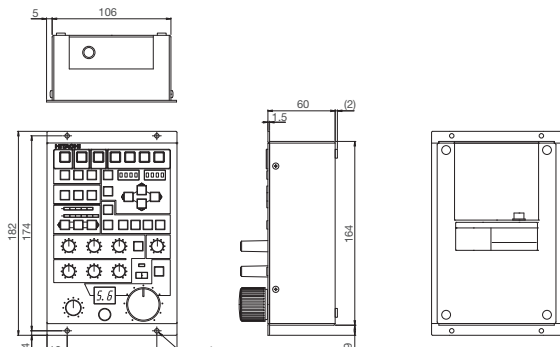

DIMENSIONS (SA-1100)

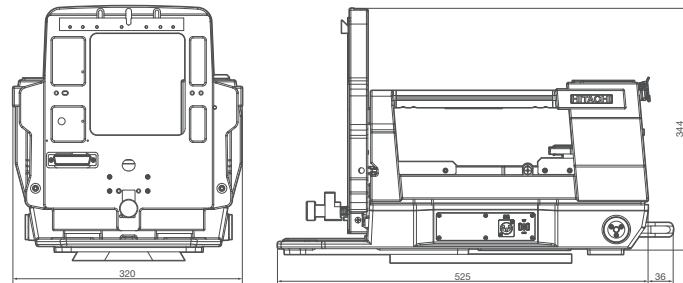

These Specifications are subject to change without notice.

CAUTION : To ensure safe operation, please read the instruction manual before using this product.

Hitachi Kokusai Electric Inc.

URL : <https://www.hitachi-kokusai.co.jp/global/en/index.html>
32, Miyuki-cho, kodaira-shi, Tokyo 187-8511, Japan
Phone : +81-50-3383-3432, Fax : +81-42-322-3303

Hitachi Kokusai Electric Asia (Singapore) Pte. Ltd.

URL: <http://www.hitachi-kokusai.com.sg/>
7 Tampines Grande, #02-02A Hitachi Square,
Singapore 528736
Phone : +65-(0)6212-1945, Fax : +65-(0)6231-2429

Hitachi Kokusai Electric America, Ltd.

URL: <http://www.hitachikokusai.us/>
Headquarters
104 Feeding Hills Road Southwick, MA 01077, U.S.A.
Toll Free : +1 (833) 227-1658,
Phone : +1 (669) 207-5038

West Office

11258 Monarch Street, Unit H
Garden Grove, CA 92841, U.S.A.

West Sales Phone : +1 (516) 682-4448

East Sales Phone : +1 (516) 682-4445

Midwest Sales Phone : +1 (516) 682-4453

South Sales Phone : +1 (516) 682-4453

Canada / Latin Sales Phone : +1 (516) 682-4408

Hitachi Kokusai Electric Europe GmbH

URL : <http://www.hitachi-keu.com/>
Frankfurt Head Office
Siemensstr. 9, D-63263 Neu-Isenburg, Germany
Phone : +49 (0) 6102-8332-0, Fax : +49 (0) 6102-202616

London Office

Orion House, Bessemer Road, Welwyn Garden City, Herts,
AL7 1HH, UK
Phone : +44 (0) 7808 330195

Hitachi Kokusai Linear Equipamentos Eletrônicos S/A

URL: <http://www.hitachi-linear.com.br/>
Rodovia BR 459, No121-A, Km 121 - Bairro Corrego Raso,
Santa Rita do Sapucaí, 37540-000, MG - Brazil
Phone : +55 (35) 3473-3473, Fax : +55 (35) 3473-3474

Hitachi Kokusai Electric

HITACHI
Inspire the Next

Multi-Format Digital HDTV Production Camera

SK-HD1300

Progressive Image Capture

HDR
HIGH DYNAMIC RANGE



Hitachi SK-HD1300

Multi-format HDTV Studio production camera

Multi-Format Digital HDTV Production Camera

SK-HD1300

Progressive Image Capture

Multi-format HDTV production camera

The SK-HD1300 is a multi-format portable HDTV Studio camera. Its new MOS sensors, each having 2.6 million pixels, provide outstanding imaging performance.

Due to Hitachi's implementation of the latest 3-MOS imaging technology, the SK-HD1300 achieves high levels in high sensitivity and has no vertical smear.

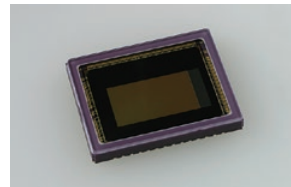

Hitachi's advanced digital signal processing

Each essential part of the Hitachi SK-HD1300 camera system has its own DSP processor. Different DSP ICs are used independently for the HDTV camera head processing, the transmission system and the Camera Control Unit (CCU) processing. The new, power-efficient Hitachi's DSP processors are designed to work with any new 2K imaging technology that is in the near future thus, offering a high R.O.I. (return on investment).

An outstanding overall signal-to-noise ratio specification of 62dB is achieved by use of our own low-noise circuit technology. The standard sensitivity is rated at F10@59.94Hz (SK-HD1300)/F11@50Hz (SK-HD1300E) with 2000 lx.

Even at high gain, clear images are obtained with little noise. Also high horizontal resolution performance of 1100TVL (Luminance channel) is the pinnacle of picture sharpness and is an attribute to the claim of having the most transparent signal processing path of any Hitachi digital camera manufactured to date.

Superb High Definition picture reproduction & enhancement tools

High Dynamic Range (HDR)

High Dynamic Range (HDR) is a significant advancement in camera technology that dramatically improves picture quality and is easily visible at all viewing distances. HDR enhances images with expanded detail in blacks, brighter highlights and more accuracy in mid-tones. The improved dynamic range contrast also increases perceived sharpness and color saturation. Multiple HDR settings for HPQ and Hybrid Log Gamma are provided for increased compatibility with legacy TVs using Standard Dynamic Range.



Luminance response tools

Black Stretch

The Black stretch function allows for better reproduction of dark or underexposed areas by evenly raising the luminance response without changing the pedestal, white clip or knee settings. It is especially useful in high contrast shooting conditions.

Digital signal transmission via Hybrid Fiber Optical Cable

The SK-HD1300 camera system utilizes industry standard Hybrid Fiber-optic cable (HFOC) connectors made of high-strength materials that ensure durability and reliable performance under the most demanding TV production conditions. The maximum HFOC length with applied camera power and fully operational facilities is 4,000m (13,200 feet) without utility power*.

The Optical power meters at the camera head, control panel and CCU front panel indicate the optical condition of both transmitting and receiving signals independently to accurately depict proximity to the "digital cliff" (maximum cable distance) or provide basic HFOC diagnostics.

*The cable distance varies depending on the system configuration when powered by the CCU. The power consumption of the lens, studio adapter, viewfinder and accessories like teleprompters reduce the available power to the camera and in turn the cable length is reduced.

Real-time Lens Aberration Correction (RLAC)

Modern HDTV lenses can still produce optical distortions. One of these called "Lateral chromatic aberration" can be reduced in certain lens models when used with the SK-HD1300 camera system.

The Hitachi function is called RLAC (Real-time Lens Aberration Correction) and it dynamically corrects images using correction data provided by the lens, through a digital interface with the camera.



Black Gamma

The Black Gamma function can control Initial gamma gain more finely than conventional black stretch. Independent Initial Gamma controls are provided for the Red, Green and Blue channels providing a fine granularity control over dark colors.

Ultra-Gamma

It dramatically increases the exposure latitude of the camera in shooting conditions where lighting and scenery vary widely in intensity. Seven different ultra-gamma responses are preprogrammed to suit just about every possible adverse shooting condition.

Color reproduction excellence

Triple-masking

The triple-masking function includes 12-vector, linear matrix and skin tone masking providing users wide latitude in subject image color control. The 12-vector color corrector provides independent control of hue and saturation for six primary and six secondary combinations of colors. A 6-axis linear matrix provides overall color control for excellent, precise color rendition control. The Skin tone masking function provides "fine painting" (hue and saturation) of skin tones without affecting other colors in the scene.

Preset Masking

The preset masking function reproduces various image color spaces such as STANDARD (Hitachi standard), ITU-709, SMPTE-240M, SMPTE-WIDE, NTSC, and EBU.

Skin-tone masking

The Skin-tone masking function provides "fine painting" (hue and saturation) of Skin tones without affecting other colors in the scene. This functions additional and independently from the linear and 12-vector-masking functions thereby adding an additional color-correction (Triple-masking) channel to the overall image color control.



Skin-tone masking OFF



Skin-tone masking ON (Simulated image)

Chroma Saturation

Total chroma saturation allows control over the amount of color in the image. A purely black & white image can also be achieved.

Knee Saturation

Washed out colors are faithfully reproduced in bright areas of the image with the Knee Saturation control.

Lens Files

The SK-HD1300 can store 8 lens files which include various lens correction data such as vertical modulation shading. This lens correction data can also be stored in a card (SD card), where it can be recalled when necessary. Picture sharpness enhancement

Picture sharpness enhancement

Absolute detail control

Hitachi provides 3 major detail controls designed to precisely place, control and shape the picture sharpness characteristics of the SK-HD1300 camera system.

Master Detail items

Master Detail items are available to adjust varied parameters of the detail signal to taste or to achieve a desired "look" in your productions. Some of these adjustments are; H/V detail, crisp, level dependence, knee detail, limiter, source, frequency and balance.

Skin-Tone Detail

The Skin-tone Detail functions allow a skin-tone color-based softening of the image to achieve the impression of more youthful TV personalities.

Three individual memories exist as well as a function to automatically detect the hue, saturation and luminance of the Skin-tone to be affected. This function is not limited to Skin-tones only; it can increase or decrease the sharpness of any pair of colors in the image. Furthermore, the Skin-tone Detail level can be adjusted to follow the lens zoom position so that a natural overall enhancement is realized at wide angle shots of the talent.



Skin tone Detail OFF



Skin tone Detail ON (Simulated image)

High-Chroma detail

The High-Chroma detail adjustments allow precise control of the detail level in highly color-saturated portions of the picture such as the petals of a rose or a colorful fabric.



High-chroma detail OFF



High-chroma detail ON (Simulated image)

Auto Chroma

Auto Chroma automatically reduces over-saturated colors in the image caused by extremely bright and colorful objects such as emergency vehicle lights or stage lighting LEDs.

Also it has the effect of 'legalizing' the color gamut of a particular preset masking setting.

Other Useful Production Camera Features



Prompter and floor monitor power

The SK-HD1300 camera system provides plenty of power to drive two 24-inch LCD monitors with either hybrid-fiber or digital triax cable CCUs.

Floor Monitor Digital Video

The studio floor or talent monitor can be driven with SDI (digital) video for critical viewing by the talent.

Professional Audio Connectors

Hitachi uses dependable XLR-professional type audio connectors for the 2 intercom headsets and 2 MIC/ LINE audio connections.

Focus Assist

Precise focus can be easily achieved by the camera operator with the aid of the Hitachi viewfinder focus assist functions. They consist of a linear bar graph on the bottom of the VF screen and detail level control just for the VF video.

Gray-Scale Automatic Setup

Hitachi's Gray-scale auto-setup accurately adjusts the video parameters of the camera by using an external known reference, under actual lighting conditions thus, optimizing the performance of the lens used. Color matching can easily be accomplished by employing this unique function.

Flexible Choice of Camera Control Units

3 different Camera Control Units (CCU) are offered for every budget, physical size and signal requirement for the SK-HD1300 camera system.

The budget priced CU-HD500 Fiber CCU is a full rack model that outputs either 1080i or (special order) 720p.

Full HD 1080 Progressive CCUs include the CU-HD1300T and CU-HD1300FT that offers fiber, triax or both camera cable options. The dual fiber and triax cable CCU is particularly suitable for venues that may have multiple cable types connecting to mobile production/OB units*. All CCUs have an easy-to-maintain modular design, employ the same control panels, data cables and peripherals.

CCU Common Features and Benefits

- Multi Format outputs :3G 1080p(50/59.94) 1.5G 1080i (50/59.94) / 720p (50/59.94) / SD-SDI (CU-HD1300FT / 1300T)
- TCP/IP Network connectivity via RJ45 (CU-HD1300T/FT, CU-HD500-S5)
- HD-SDI and SD-SDI outputs
- 4 auxiliary returns (CU-HD1300T/FT)
- Dedicated teleprompter channel
- SMPTE color bar output
- 2 channel balanced analog Mic audio outputs or embedded HD-SDI digital audio
- Genlock with composite or tri-level sync
- 2-tally (Red/Green) system.
- 2-channel, 2W/4W intercom system.
- RS-232C remote control (CU-HD500)

* (See detailed specifications on the last page of this brochure)

CU-HD1300FT/CX-HD1300/CA-HF1300 Digital Triax and Fiber System

- CCU Status OPT&TRX LED indicators show cable condition on front panel.
- Triax/Fiber dual-purpose CCU equips both Triax and Fiber connectors and transmit 3G (1080p) video.

Triax Mode

- Multilevel digital modulation technology transmits high bitrates signal Multi-format Long distance transmission with Triax cable up to 1800 m (@ 14.5 mm FUJIKURA), 900 m @ 8.6 mm FUJIKURA, 1250 m @ 11 mm DRAKA and 1150 m @ 11.0 mm NK NETWORKS, 700 m @ 9.1 mm BELDEN, 1200 m @ 13.2 mm BELDEN (1080i).
- Ultra-Low latency H.264 codec
Less than 1 field (<20 ms) latency by multi-slice ultra-Low latency H.264 codec.

Fiber Mode

- With 9.5 mm SMPTE 311 cable up to 4000 m video transmission
- With Single mode fiber up to 10,000 m video transmission

CU-HD1300FT



CU-HD1300FT Front Panel



CU-HD1300FT Rear Panel (Fiber/Triax)

CU-HD500 / CU-HD500-S5



CU-HD500 Front Panel



CU-HD500 Rear Panel

Option Model

4K format (50/59.94) : CU-HD1300FT-S1
 Back lit rear panel : CX-HD1300/CA-HF1300
 Delivery in six months after order

4K ULTRA HD

Large lens adaptor

The SA-1100 serves primarily as a mechanical large lens supporter and it also offers these important features: the ability to use "Hanger-type" box lenses and "Bayonet-type" hand-held portable lenses without removing the camera from the actual SA-1100.

Functions routinely required by the cameraperson in Studio and Field production are brought out from the camera menu and presented in the SA-1100's rear operation panel for easy access. This Studio Adaptor includes a "Cable-less" and "tool-less" camera interface which increases the systems' reliability and retains the flexibility of having multiple choices for viewfinders when using big lenses.



SA-1100 Rear Panel
 (with CA-HF1300/HDF-EL800H)

System configuration chart

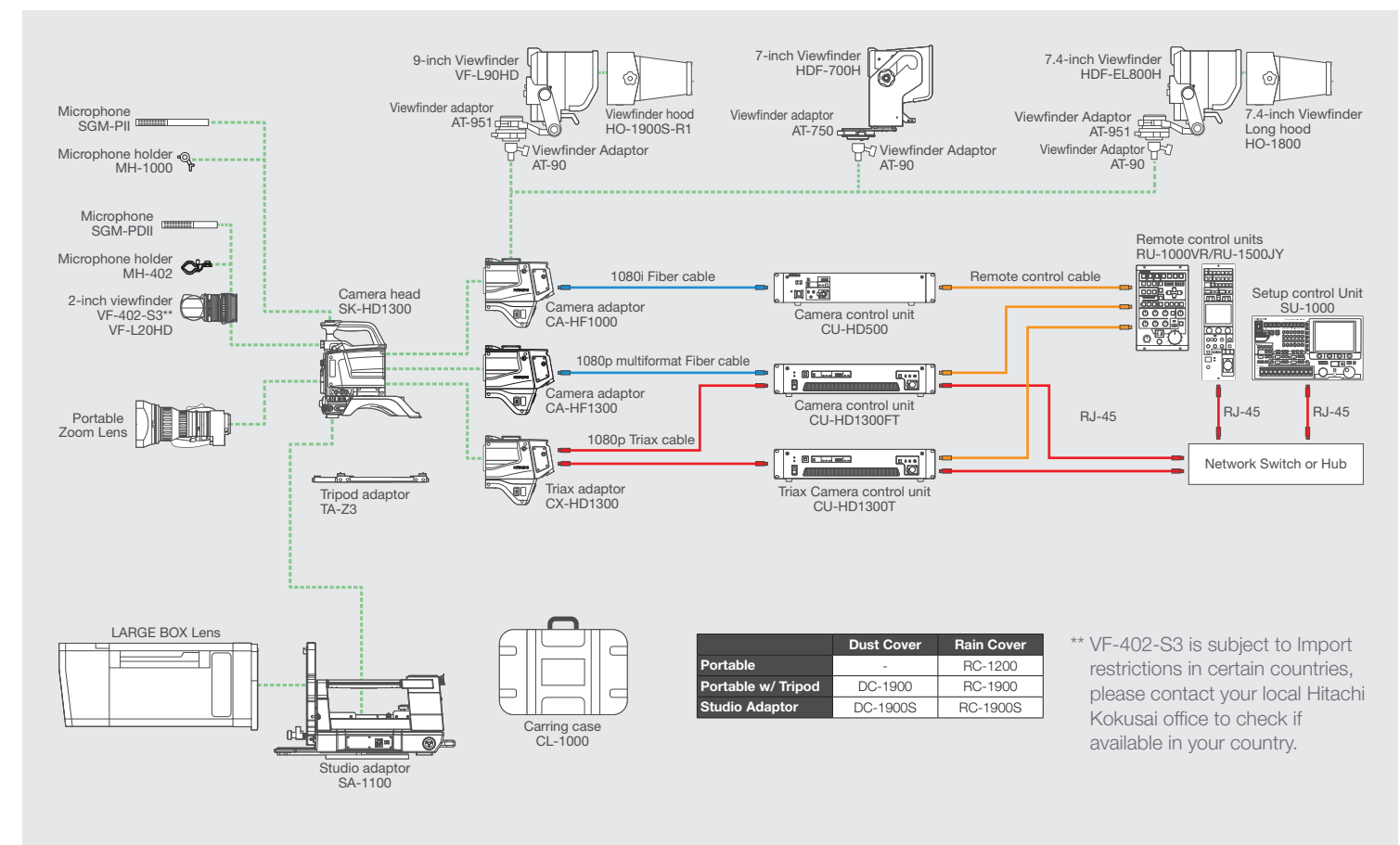

	Dust Cover	Rain Cover
Portable	-	RC-1200
Portable w/ Tripod	DC-1900	RC-1900
Studio Adaptor	DC-1900S	RC-1900S

** VF-402-S3 is subject to Import restrictions in certain countries, please contact your local Hitachi Kokusai office to check if available in your country.

SPECIFICATIONS

Progressive Capture Camera Head

Camera Head SK-HD1300 / SK-HD1300E		
Model Name	SK-HD1300	SK-HD1300E
Imaging Device	2/3-inch, MOS image sensor Total pixels : 2,270(H) x 1,144(V) 2.6 million pixels	
TV System	1,920(H) x 1,080(V) / 59.94i/p 1,920(H) x 1,080(V) / 50i/p	
Optical system	F1.4 prism	
Optical Filters	1x motorized filter wheel w/4 filter positions Clear, Cross, 1/16ND, 1/64ND ECC (Electronic Color Correction) with 5 settings (3200K, 4300K, 5600K, 6300K, 8000K)	
Sensitivity	F10 @ 2000 lx (3200 K, 89.9% reflectance)	F11 @ 2000 lx (3200 K, 89.9% reflectance)
Signal to Noise Ratio	62dB (1080i) (typical)	
Resolution	Horizontal : 1100TVL , Vertical : 1000TVL	
Registration	0.01 % (excluding lens characteristics)	
Lens mount	B4 bayonet-type	
Gain selection	L (low) -3, 0dB M (medium) 0, +3, +6, +9, +12, +15, +18, +21dB H (high) +3, +6, +9, +12, +15, +18, +21, +24dB	
Electronic Shutter	1/100, 1/250, 1/500, 1/1000, 1/2000, AES	1/60, 1/250, 1/500, 1/1000, 1/2000, AES
Dimensions	133 (W) x 191 (H) x 262 (D) mm	
Operating temperature	-10°C to +45°C, 14°F to 113°F	
Input & Output	1x BNC HD-SDI VF out (Character ON/OFF) or HD-SDI RET out 4-pin Multi connector for remote control panel 20-pin Multi VF connector, 12-pin Multi LENS connector 3-pin XLR MIC-1 connector, SD Memory Card Slot	
Power consumption	Camera head 18 W Head only (without VF)	
Mass	2.1kg, 4.6lbs. Camera head	

SK-HD1300-S2/SK-HD1300E-S2

Optical Filters : 2x motorized filter wheel with 5 filter positions
ND CAP, 1 : Clear, 2 : 1/4ND, 3 : 1/16ND, 4 : 1/64ND
CC A : CROSS, B : 3200K, C : 4300K, D : 6300K, E : 8000K

Triax Camera Adaptor CX-HD1300

CCU connector	1x-Triax connector
Video transmission system	Fully digital bi-directional, 10-bit, 4 : 2 : 2 sampling, 3G (1080p50/59.94)
Intercom	2x channel, 5-pin each XLR, MIC on/off, ENG/PD level control, Tracker level control
Program audio	2x, PGM audio level controls w/ Chnl1 & Chnl2 intercom mix
Teleprompter power output	1x 5-pin, 230 VAC, 60 W to 100 W, external prompter Tally drive out (depending on configuration accessories)
Microphones	Chnl1 & 2, Line or MIC level select (MENU), with +48 V phantom power on/off
Return/ Aux switcher	Remote AUX / VF video select connector (RET control)
Video Inputs & Outputs	2x HD-SDI1/3 OUT, 3G-SDI/HD-SDI •3G-SDI (1080p50/59.94): SMPTE424/425 Level-A •HD-SDI (1080i50/59.94): SMPTE292M 1x HD-SDI2 OUT 3G-SDI or HD-SDI •3G-SDI (1080p50/59.94): SMPTE424/425 Level-A •HD-SDI (1080i50/59.94): SMPTE292M 1x SD analog prompter out shared with Genlock in
Other I/O	1x 29-pin (for SA-1000 cable-less interface) (female) 1x 5-pin script lamp +12 VDC (1.0 A max) (female) 1x 6-pin VF AUX return (female) (for use in cranes or extended Head / VF configurations) 1x XLR 4-pin, 12VDC power input (male)
Dimensions	142 (W) x 188 (H) x 202 (D)
Mass	2.6 kg, 5.7 lbs. approx.
Operating Temperature	-10 °C to +45 °C, +14 °F to +113 °F

1080p Multi-format system

Fiber Camera Adaptor CA-HF1300	
CCU connector	1x-type HFOC female connector (LEMO) SMPTE-304M-type
Intercom	2x channel, each XLR 5-pin, channel selection, MIC on/off, volume
Program audio	2x, PGM audio level controls w / Chnl1 & Chnl2 intercom mix
Teleprompter power output	1x 5-pin, AC230 V, 100 VA, external prompter R/G Tally drive out (depending on configuration accessories)
Microphones	Channel 1 & 2 Line or MIC level select (MENU), with +48 V phantom power on/off
Return/ Aux switcher	4-input remote AUX / VF video select connector (RET control)
Video Inputs & Outputs	1x 3G HD-SDI OUT, 1X SD analog teleprompter out shared with Genlock in, 1x HD-SDI RET OUT
Other I/O	1x 29-pin (for SA-1100 cable-less interface) (female) 1x 5-pin script lamp DC12 V (1.0 A max) (female) 1x 6-pin VF AUX return (female) (for use in cranes or extended Head / VF configurations) 1x XLR 4-pin, DC12 V power input (male)
Dimensions	133 (W) x 189 (H) x 194 (D) mm
Mass	2.2 kg, 4.8 lbs. approx.
Operating temperature	-10°C to +45°C, 14°F to 113°F

Camera Control Unit CU-HD1300FT/ CU-HD1300T

GENLOCK IN	1x BNC • B-BST 0.45Vp-p/75Ω (loop through) • HDTV tri-level sync 0.60Vp-p/75Ω (loop through)
RETURN IN (1/2/3/4) RETURN B IN (1/2)	2x BNC, 3G-SDI/HD SDI(1080i or 720P) / SD SDI • 3G-SDI: SMPTE424/425 Level-A • HD-SDI: SMPTE292M • SD-SDI: SMPTE259M-C NOTE: RETURN (3/4) and RETURN B (1/2)are provided by CU-HD1300FTE and CU-HD1300FE
PROMPT IN	1x BNC, VS or VBS 1.0Vp-p/75Ω (loop through)
HD/SD OUT (1/2/3)	6x BNC, 3G-SDI(1080p)/HD-SDI (1080/25p, 1080/25PsF, 1080i or 720p) / SD-SDI selectable (Embedded audio available) • 3G-SDI: SMPTE424/425 Level-A • HD-SDI: SMPTE292M • SD-SDI: SMPTE259M-C
PIX/WFW OUT	1x BNC, 3G-SDI/HD-SDI (1080i or 720p)/SD-SDI selectable (Embedded audio available) • 3G-SDI: SMPTE424/425 Level-A • HD-SDI: SMPTE292M • SD-SDI: SMPTE259M-C
MIC OUT 1 MIC OUT 2	1x XLR, 3-pin, 0dBm/ 600Ω 1x XLR, 3-pin, 0dBm/ 600Ω
INTERCOM (HEAD SET)	1x XLR, 5-pin, 0dBu Max +15dB
REMOTE 1 REMOTE 2 REMOTE 3	1x 4-pin, 1.5Vp-p or 1x D-sub, 9-pin RS-232C (Switchable) 1x 4-pin, 1.5Vp-p 1x RJ-45
COMMUNICATION • INTERCOM	1x D-sub 25-pin 0dBm , 600 Ω at 4Wire 0dBu or -15dBu ,200 Ω at 2Wire (ENG, PD and PGM)
TALLY OUT (R/G)	1x D-sub 9-pin, Contact 24 Vdc, 10 mA
WFM CONTROL	1x D-sub 15-pin WFM 0-7, 0/5V
Power supply voltage	100 to 240 VAC 47 to 63Hz(with auto-sensing mode)
Mass	11 kg, 24.3 lbs. approx.
Dimensions	432 (W) x 88 (H) x 419 (D) mm, 2 RU
Operating temperature	0°C to 40°C, 32°F to 104°F
Power consumption	300W approx. (AC operation, including SK-HD1300, VF-402 and AUX POWER OUT 100VA)

1080i system

Camera Control Unit CU-HD500U (59.94Hz) / CU-HD500E (50Hz)	
Genlock	1x BNC, B-BST 0.45Vp-p/75Ω (loop through) HDTV tri-level sync 0.60Vp-p/75Ω (loop through)
Digital Return 1/2	1x BNC, HD SDI or SD SDI
Prompt	1x BNC, VS or VBS 1.0Vp-p/75Ω (loop through)
Intercom (Headset)	5-pin XLR, -60dBm
Communication	1xD-sub 25-pin,Incom,Tally
Intercom PGM R/G TALLY	0dBm / 600Ω at 4Wire, 0dbu or -15dbu / 200Ω at 2Wire 0dBm / 600Ω Contact or DC supply
Digital Out	2x BNC, HD-SDI (Embedded audio available) 4x BNC, HD-SDI or SD-SDI selectable (Embedded audio available) HD-SDI or SD-SDI selectable PIX (Embedded audio available)
MIC OUT 1/MIC OUT 2	1x XLR, 3-pin, 0dBm/ 600Ω
Intercom (headset)	1x XLR, 5-pin, 0dBu Max +15dB
Remote 1/Remote 2	1x 4-pin, 1.5Vp-p
MIC REMOTE	1x D-sub 15-pin MIC1.2 GAIN
TALLY OUT	1x D-sub 9-pin
R/G Tally	Contact or Voltage selectable
WFM control	1x D-sub 15-pin WFM 0-7, 0/5V
Power supply voltage	CU-HD500U AC117V / CU-HD500E 230V
HFOC maximum cable distance	1,000 meters (3,280 feet) with CCU power*
Operating temperature	0°C to 40°C, 32°F to 104°F
Power consumption	300W approx.(AC operation, including SK-HD1300, VF-402 and AUX POWER OUT 100VA)
Mass	9kg, 19.8lbs

* 6km (with normal single fiber)

Studio Adaptor SA-1100

Dimensions	320(W) x 344(H) x 525(D) mm approx.
Power Consumption	2.0W approx. (excluding Lens, Viewfinder, Camera, DC output)
Mass	16.5kg, 36.4lbs approx. (excluding Lens, Viewfinder and Camera)
DC output	DC12V±10% MAX 2.5A DC5V±10% MAX 0.8A
Operating temperature	-10 °C to +45 °C, +14 °F to +113 °F
Operating humidity	30 to 90 %RH
DC input	DC12V±10%

DIMENSIONS (SK-HD1300 with CA-HF1300)

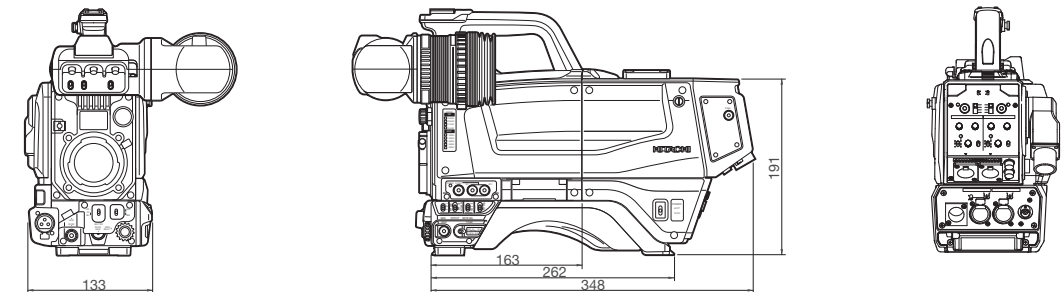

DIMENSIONS (HDF-EL800H)

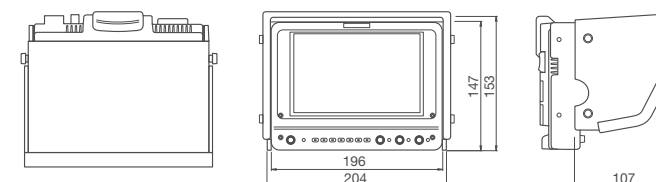

View Finder

2-inch Color Viewfinder VF-L20HD	
Display device	2-inch color TFT LCD (16:9)
Number of pixels	960 (H) x 540 (V)
Functions	Bright, Contrast, Peaking, knobs VR front-facing Dioptr
Internal tally	Red / Green
Tally switch	Tally switch OFF, NORMAL, HIGH
Power Consumption	Approx. 5.0 W (at Heater-OFF) 6.5 W (at Heater -ON)

7-inch Viewfinder HDF-700H

Picture Resolution	800 (H) x 480 (V)
Input Signals	Analog Y/Pb/Pr
Internal tally	Red/Green
Dimensions	195 (W) x 153 (H) x 50 (D)mm
Mass	1.0kg, 2.2lbs approx.

7.4-inch Color OLED viewfinder HDF-EL800H

TV system	59.94/50Hz, 1080p/1080i/720p auto-switching
Construction	7.4-inch Color OLED 960 (H) x 540 (V), 16:9
Camera mounts	AT-951(mass : 1.6kg, 3.5lbs AT-90 (mass : 0.7kg, 1.54lbs)
Functions	Bright, Contrast, Peaking, knobs VR (front-facing) ZEBRA, MARKER, UTIL (Waveform/Vector/Audio indicator)
Internal tally	Red/Green
Front tally controls	Tally OFF, NORMAL, HIGH
Dimensions	215 x 158 x 51.5mm (main body)
Mass	1.25kg, 2.8lb

DIMENSIONS (HDF-700H)

